

MAD Ltd

Bowler Range of Pan & Tilt Heads

User Manual

Contents	Page
General Information	1
Items Supplied	1
Variants	1
Compatibility with other products	1
Fitting a Housing	2
Mounting a Bowler	3
Safety Precautions	4
Control Connections	5
Setting up a Bowler	7

Metham Aviation Design Limited, Station Approach, Four Marks, Alton. Hants. GU34 5HN

Tel +44 (0) 1420 565618. Fax +44 (0) 1420 565628

General Information

The Bowler range of miniature pan & tilt heads consist of 24Vdc and 12Vdc units, in both over the top and sidemount configurations. All versions are available as continuous rotation. The sidemount version is capable of carrying 10Kg, and over the top mount 6Kg

The units are extremely compact (only one third the volume of a Topper), are externally robust, and aesthetically designed to IP68, providing a rugged and stable mobile camera platform for use in most CCTV installations, where a smaller, more discreet pan & tilt head is required.

A fresh design approach has introduced a simple but effective, externally adjustable limit switch facility and larger bearings with a broader spread, which allows much higher load capacities when configured in the sidemount configuration

Items Supplied

Mating connector
Copy of this Manual

Variants

AC Models:
Not Available

DC Models:
12 Volts & 24 Volts
Pan Speeds (Degs/sec)
10, 30
Tilt Speeds (Degs/sec)
10

Sidemount or Over the top mount, Pre-set positioning & Colour Options are available on all models. Continuous available on all models

Compatibility with other MAD Products

710 Mounting Bracket

Fitting a Housing

The camera mounting platform is provided with slots and slots on the over the top version. All holes and slots are to suit M6 bolts. The arrangement of slots are shown below.

Over The Top Mount

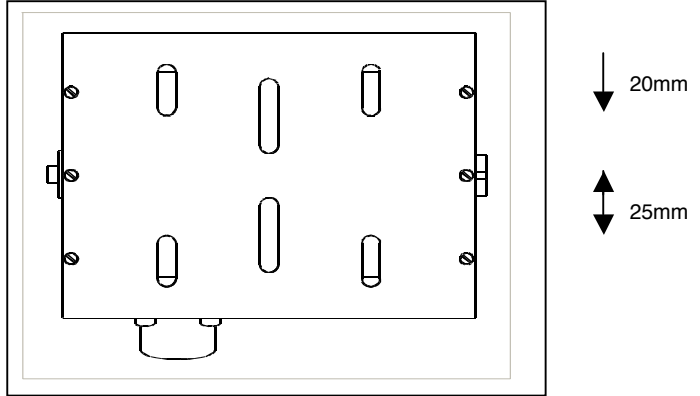

The camera mounting platform for sidemount consists of M6 clearance holes only. The arrangement of these holes are shown below

Sidemount

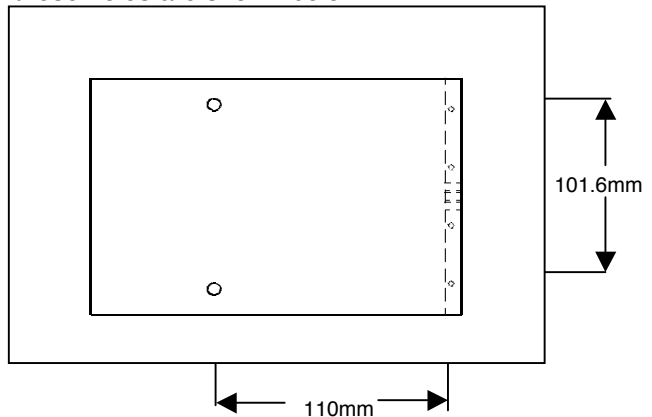

Mounting A Bowler

The standard Bowler Pan & Tilt head has a base fixing that requires 3 x M6 bolts and washers. These fixings are on a 70mm PCD as shown below left. The continuous rotation bowler pan & tilt head has a base fixing that requires 4 x M6 bolts and washers. These fixings are on a 101.6mm PCD as shown below right.

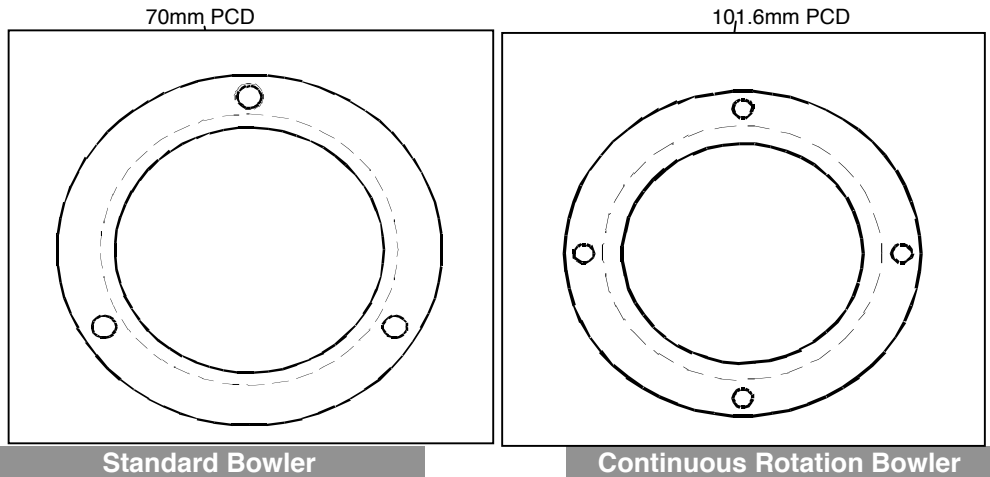

When mounting a Bowler Pan & Tilt unit, additional considerations are required. A fully loaded pan & tilt camera assembly may weigh up to or above 15Kg. Additional allowances may be required for adverse weather conditions such as ice & snow and high winds. Careful consideration must therefore be made to the location of the camera position.

Once the camera location has been established, a suitable bracket of sufficient load capacity and rigidity is required.

The surface of the camera location must be in first condition and suitable for the purpose, with no crumbling mortar or brick. The mounting bracket should be attached to the mounting position with suitable heavy duty rawl bolts.

The size of the camera head, and in particular the camera housing must be given sufficient clearances to ensure no obstructions occur. The motor and gearbox assemblies used in the Bowler range are designed to be "stalled", but continuous abuse will cause damage.

The pre-sets are centered before being shipped. The base mount on both heads allow unit to be centered on field of view before being finally clamped.

Safety Precautions

All persons installing and maintaining this equipment should be suitably qualified and work to national and local standards and codes of practice

The equipment is subject to remote control and may be operated at any time Persons working on the equipment should take appropriate precautions to ensure that any unexpected movement does not occur as this could lead to injury.

In locations or areas where the risk of Injury occurs, or any part of the assembly may become detached or fall for any reason, a strong safety chain or wire hawser should be attached between the equipment and the mounting surface. At all times, normal safety precautions must be employed.

Hazardous voltages are present in this equipment and may also be present in any associated items.

Cabling of the correct type as specified in this manual, and as by national and local standards and codes of practice. Cables should be checked for wear at 6 monthly intervals and replaced as necessary.

All fixings and fastenings must be thoroughly checked for tightness one month following installation, and thereafter at regular 6 monthly intervals.

Control Connections

The Bowler range are available in both pre-set and non pre-set versions. Both Pre-set and non pre-set versions have a 12 way Binder or a 15 way Cannon chassis connector fitted..

The continuous rotation version has an 18 way & a 9 way connector on the base tube of the unit and a 12 way binder chassis connector on the head.

The connectors must be assembled correctly to ensure that there is no water ingress through the connectors. This is very important as this can cause extreme problems within the pan and tilt unit.

Binder chassis plug 12 way connections

Pin	Function	Pin	Function
1	Pan motor +	7	Tilt brake +
2	Pan motor -	8	Tilt brake -
3	Pan brake +	9	Preset supply +5v
4	Pan brake -	10	Pan preset feedback
5	Tilt motor +	11	Tilt preset feedback
6	Tilt motor -	12	Preset supply 0v

Cannon chassis plug 15 way connections MS3112-E14-15P

Pin	Function	Pin	Function
A	Pan motor +	G	Tilt brake +
B	Pan motor -	H	Tilt brake -
C	Pan brake +	J	Preset supply +5v
D	Pan brake -	K	Pan preset feedback
E	Tilt motor +	L	Tilt preset feedback
F	Tilt motor -	M	Preset supply 0v

In common with all modern pan & tilt heads employing regenerative braking it is **ESSENTIAL** that the polarity of the braking circuits are wired in sympathy with the motor circuits. Failure to do so will result in bending the limit stop pin

Connections for a continuous rotation DC head with braking

Base Section (Static)

9 Pin Plug

Function	Pin No
Pan Right +12/24v*	1
Pan Left 0v	2
Pan Brake +12/24v*	3
Pan Brake 0v	4
Tilt Up +12/24v*	5
Tilt Down 0v	6
Tilt Brake +12/24v*	7
Tilt Brake 0v	8
N/C	9

* Depending on unit specification.

18 Pin Plug

Function	Colour
Video	1
Video screen	2
Pan pre-set feedback	3
Tilt pre-set feedback	4
User 1	5
User 2	6
no connection	7
User 3	8
User 4	9
User 5	10
User 6	11
Pre-set supply 0v	12
User 7	13
User 8	14
no connection	15
no connection	16
Pre-set supply +5v	17
no connection	18

Head Section (Rotating)

12 Pin Plug

Function	Pin No
Video	1
Video screen	2
User 1	3
User 2	4
Pre-set supply +5v	5
Pre-set supply 0v	6

12 Pin Plug

Function	Pin No
User 3	7
User 4	8
User 5	9
User 6	10
User 7	11
User 8	12

Setting Up A Bowler

For the purposes of identification, the rear of the Pan & Tilt head is the face containing the connector. When viewed from the top, anti-clockwise movement is left, and clockwise movement is right.

The Bowler Pan & Tilt Head is fitted with external pan and tilt limit stops. (continuous rotation is on the tilt only). These stops actuate an internal micro switch via a pivoting pin. This systems provides an accurate and simple method of limit stops which are extremely easy to set. It is not necessary to power down or gain access to the internal mechanism of the pan & tilt head to set up the limit stops

To set both pan and tilt limit stops, the following procedures need to be followed.

To set the panning angle of travel (Non continuous rotation)

Drive the pan & tilt head to the extreme left hand position required. Slide the top actuator spring until it engages and actuates the micro switch pin. This limit is now set. Now drive the pan & tilt unit to the extreme right hand position required. Adjust the bottom actuator spring until it engages and actuates the micro switch pin. This limit is now set. Drive the pan & tilt unit to the extreme limits of travel in both directions and check operation of the limit switches. Re-adjust if required.

To set the tilt angle of travel (all models)

Drive the pan & tilt head to the upper-most position required. Slide the rear actuator spring until it engages and actuates the micro switch pin. This limit is now set. Drive the unit to the lowest point required and slide the front actuator spring until it engages and actuates the micro switch pin. This limit is now set. Drive the pan & tilt unit to the extreme limits of travel in both directions and check operation of the limit switches. Re-adjust if required.

*** The actuator pins are designed to slip in one direction more easily than the other. Observe this characteristic and ensure that the limits are operated in the direction that tightens the spring on the shaft.**